

DAIKIN



OPERATION MANUAL

VRV System Inverter Air Conditioners

FXNQ20A2VEB
FXNQ25A2VEB
FXNQ32A2VEB
FXNQ40A2VEB
FXNQ50A2VEB
FXNQ63A2VEB

CONTENTS

READ BEFORE OPERATION

Part name and functions	2
Safety precautions.....	2

MAINTENANCE

Maintenance and inspection.....	3
Cleaning the inside of the indoor unit.....	3
Cleaning the air filter	3
Cleaning the air outlet and exterior	4
Troubleshooting.....	4
Specifications	5

AFTER SALES SERVICE

After-sales service and maintenance	5
---	---

READ BEFORE OPERATION

Part name and functions

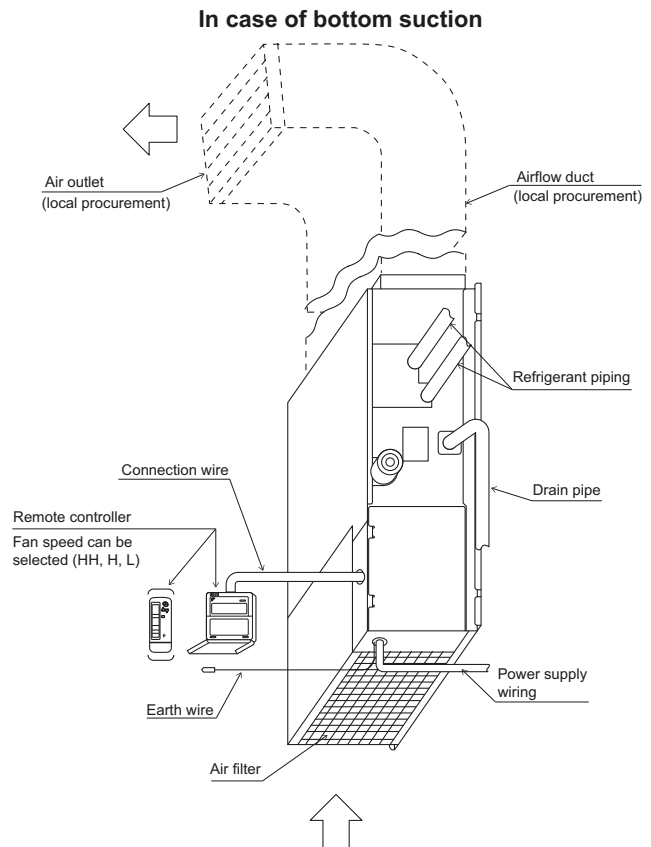
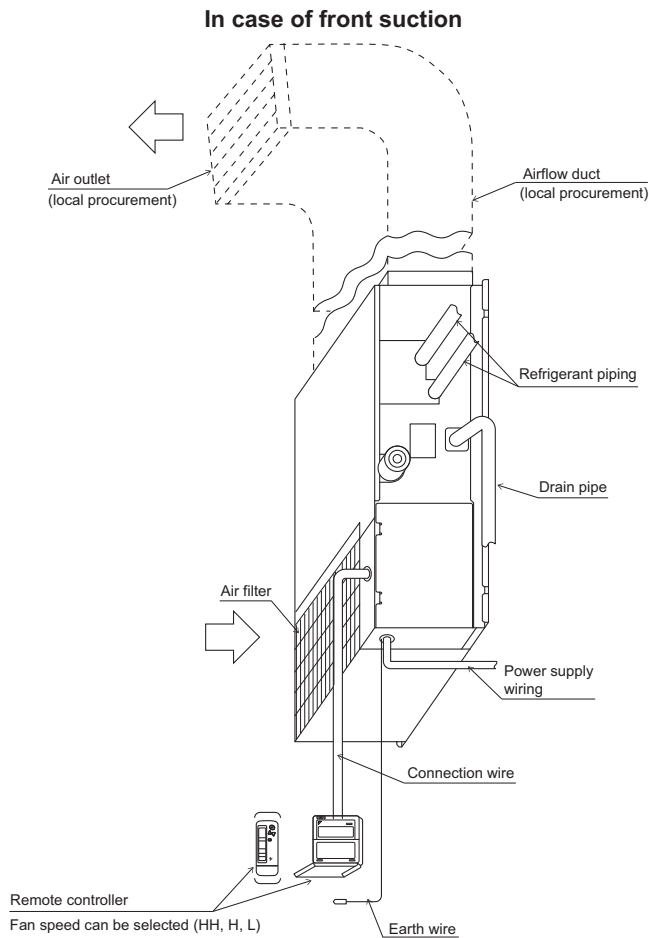

Safety precautions

To gain full advantage of the air conditioner's functions and to avoid malfunction due to mishandling, we recommend that you read this instruction manual carefully before use.

- This air conditioner is classified under "appliances not accessible to the general public".
- **The precautions described herein are classified as WARNING and CAUTION. They both contain important information regarding safety. Be sure to observe all precautions without fail.**

⚠ WARNING Failure to follow these instructions properly may result in personal injury or loss of life.

⚠ CAUTION Failure to observe these instructions properly may result in property damage or personal injury, which may be serious depending on the circumstances.

After reading, keep this manual in a convenient place so that you can refer to it whenever necessary. If the equipment is transferred to a new user, be sure also to hand over the manual.

— ⚠ WARNING —

- **Consult your local dealer about installation work.**
Doing the work yourself may result in water leakage, electric shocks or fire hazards.
- **Consult your local dealer regarding modification, repair and maintenance of the air conditioner.**
Improper workmanship may result in water leakage, electric shocks or fire hazards.
- **Beware of fire in case of refrigerant leakage.**
If the air conditioner is not operating correctly, i.e. not generating cool or warm air, refrigerant leakage could be the cause. Consult your dealer for assistance. The refrigerant within the air conditioner is safe and normally does not leak. However, in the event of a leakage, contact with

a naked burner, heater or cooker may result in generation of noxious gas.

Do not longer use the air conditioner until a qualified service person confirms that the leakage has been repaired.

- **Consult your local dealer regarding relocation and reinstallation of the air conditioner.** Improper installation work may result in leakage, electric shocks or fire hazards.
- **This appliance is not intended for use by persons, including children, with reduced physical, sensory or mental capabilities, or lack of experience and knowledge, unless they have been given supervision or instruction concerning use of the appliance by a person responsible for their safety.** Children shall be supervised to ensure that they do not play with the appliance.

—  **CAUTION** —

- **Do not place objects in direct proximity of the outdoor unit and do not let leaves and other debris accumulate around the unit.** Leaves are a hotbed for small animals which can enter the unit. Once in the unit, such animals can cause malfunctions, smoke or fire when making contact with electrical parts.
- **This appliance is intended to be used by expert or trained users in shops, in light industry and on farms, or for commercial use by lay persons.**

MAINTENANCE

—  **WARNING** —

- **Only a qualified person is allowed to perform maintenance without daily maintenance.**
- **Before touching any of connection wirings, be sure to turn off all power supply switches.**
- **Do not use flammable materials (e.g., hair-spray or insecticide) near the product. Do not clean the product with organic solvents such as paint thinner.** The use of organic solvents may cause crack damage to the product, electric shocks, or fire.
- **Contact professional personnel about attachment of accessories and be sure to use only accessories specified by the manufacturer.** If a defect results from your own workmanship, it may result in water leaks, electric shock or fire.

—  **CAUTION** —

- **Before cleaning, be sure to stop unit operation, turn the breaker off or remove the power cord.** Otherwise, an electric shock and injury may result.
- **Do not wash the air conditioner with water, as this may result in electric shocks or fire.**
- **Consult your dealer regarding cleaning the inside of the air conditioner.** Improper cleaning may cause breakage of plastic parts, water leakage and other damage as well as electric shocks.
- **Watch your steps at the time of air filter cleaning or inspection.** High-place work is required, to which utmost attention must be paid. If the scaffold is unstable, you may fall or topple down, thus causing injury.

Maintenance and inspection

- Clean the drain pan periodically. The drain pipes clogged with dust will cause water leakage.
- For cleaning, consult with your Daikin dealer. (Before each season when cooling or heating is required, clean the air conditioner.)
- If the area around the indoor unit is very dusty, use a dust-proof cover (local procurement).

Cleaning the inside of the indoor unit

- It is necessary to clean the inside of the indoor unit periodically. Since the cleaning requires special technologies, request a Daikin dealer to clean them.

Periodic maintenance:

Cleaning the air filter

Explanation

- Removing the air filter except when cleaning the air conditioner may result in accidents.
- When the  mark is displayed on the remote controller, please clean the filter.
- When the operating time exceeds the designated time, this mark will be displayed.
- If using the air conditioner under very dusty environment, increase the frequency of air filter cleaning.

- When you want to change the setting time until the  mark is displayed, consult with your dealer.
(The default factory setting is 2500 hours.)
- There are the following time, display pattern.
1250, 2500, 5000, 10000

1. Remove the air filter.

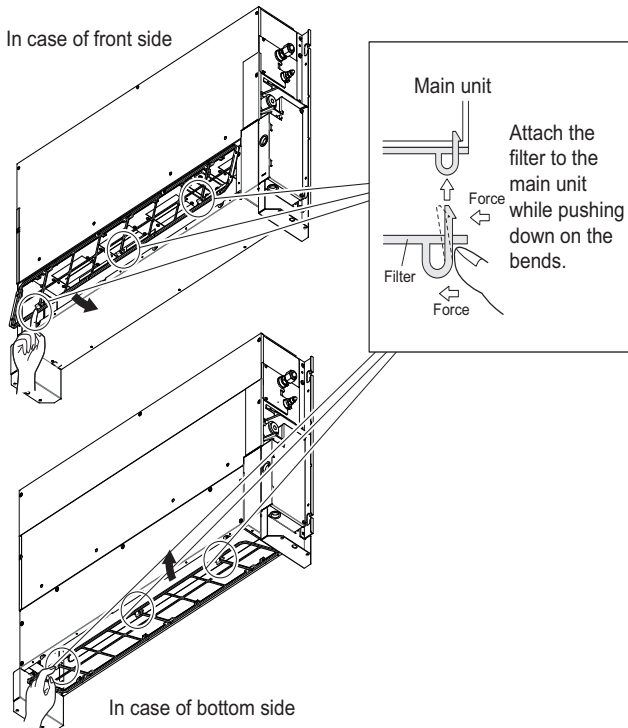

2. Clean it.

⚠ CAUTION

- Do not wash the air conditioner with hot water of more than 50°C. Doing so may result in discoloration or deformation.
- Never dry the filter by direct firing. Doing so may result in burning.
- For cleaning local procurements, consult with your dealer.

(1) Use a vacuum cleaner (A) or wash the air filter (B) to remove dust and trash.

(A) Remove dust and trash using a vacuum cleaner.



(B) Wash it with water.

When the air filter is very dirty, use a soft brush and neutral detergent.



Dewater and dry in the shade.



3. Attach the air filter.

4. Push the “filter sign reset” button on the remote controller.

The display “” vanishes.

Cleaning the air outlet and exterior

⚠ CAUTION

- Do not use gasoline, benzene, thinner, polishing powder or liquid insecticide.
- Do not use hot water of 50°C or higher, as doing so may result in discoloration or deformation.

(1) Clean with dry soft cloth.

(When it is difficult to remove stains, use water or neutral detergent.)

Troubleshooting

If the following phenomenon occurs, contact your dealer.

⚠ WARNING

- **When the air conditioner is malfunctioning (giving off a burning odour, etc.) turn off power to the unit and contact your local dealer.**

Continued operation under such circumstances may result in a failure, electric shocks or fire hazards.

- **Contact your dealer.**

Phenomenon

- If a safety device such as a fuse, a breaker or an earth leakage breaker actuates;
Take the following actions before contact.
Do not turn on the main power switch.
- If the ON/OFF switch does not properly work;
Take the following actions before contact.
Turn off the main power switch.

Phenomenon

- Water leaks out from the air conditioner.
Take the following actions before contact.
Stop the operation.

Phenomenon

- The “OPERATION lamp”, “INSPECTION display” or “UNIT No.” is winking and lit, and “MALFUNCTION CODE” is displayed.

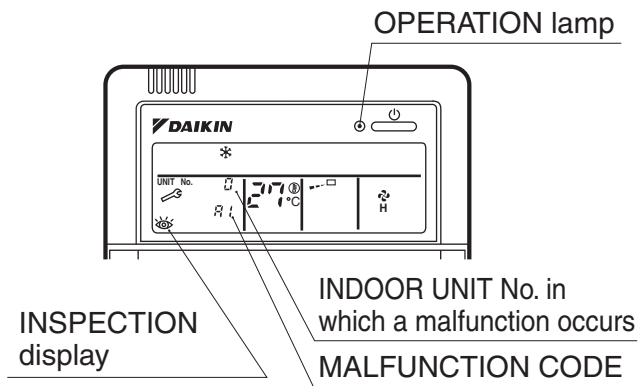

Take the following actions before contact.
Inform the dealer of the details being displayed on the remote controller.

Specifications

Product type and running noise

Model		Model No.					
		20	25	32	40	50	63
Type	Function	Heat pump type					
	Combination system	Separate type					
	Condenser cooling method	Air cooling type					
	Air blowing method	Direct air-blowing type					
	Rated cooling capacity (W)	2200	2800	3600	4500	5600	7100
	Rated heating capacity (W)	2500	3200	4000	5000	6300	8000

AFTER SALES SERVICE

After-sales service and maintenance

— ⚠ WARNING —

- **Consult your local dealer regarding modification, repair and maintenance of the air conditioner.**
Improper workmanship may result in water leakage, electric shocks or fire hazards.
- **Consult your local dealer regarding relocation and reinstallation of the air conditioner.**
Improper installation work may result in leakage, electric shocks or fire hazards.
- **Beware of fire in case of refrigerant leakage.**
If the air conditioner is not operating correctly, i.e. not generating cool or warm air, refrigerant leakage could be the cause.
Consult your dealer for assistance.
The refrigerant within the air conditioner is safe and normally does not leak.
However, in the event of a leakage, contact with a naked burner, heater or cooker may result in generation of noxious gas.
Do not longer use the air conditioner until a qualified service person confirms that the leakage has been repaired.
- **When asking your dealer to repair, inform related staff of the details as follows:**
 - Product No. of air conditioner:
Refer to the warranty card.
 - Shipping date and installation date:
Refer to the warranty card.
 - Malfunction:
Inform the staff of the defective details. (Malfunction code being displayed on the remote controller.)
 - Name, address, telephone number
- **Repair where the warranty term is expired**
Contact your dealer. If necessary to repair, pay service is available.
- **Minimum storage period of important parts**
Even after a certain type of air conditioner is discontinued, we at Daikin have the related important parts in stock for 9 years at least.
The important parts indicate parts essential to operate the air conditioner.
- **Maintenance and inspection**
Since dust collects after using the unit for several years, the performance will be deteriorated to some extent.

It is recommended to request the technical staff to perform maintenance (pay service). For further details, consult with your dealer.

• **Where to call**

For after-sales service, etc., consult with your dealer.

• **When disposing the air conditioner, removing/installing and maintaining it, collect the refrigerant.**

Call the service shop immediately.

⚠ WARNING

• **When an abnormality (such as a burning smell) occurs, stop operation and turn the breaker OFF.**

Continued operation in an abnormal condition may result in troubles, electric shocks or fire. Consult the service shop where you bought the air conditioner.

• **Do not attempt to repair or modify the air conditioner by yourself.**

Incorrect work may result in electric shocks or fire.

Consult the service shop where you bought the air conditioner.

If one of the following symptoms takes place, call the service shop immediately.

- The power cord is abnormally hot or damaged.
- An abnormal sound is heard during operation.
- The safety breaker, a fuse, or the earth leakage breaker cuts off the operation frequently.
- A switch or a button often fails to work properly.
- There is a burning smell.
- Water leaks from the indoor unit.



Turn the breaker OFF and call the service shop.

- After a power failure
The air conditioner automatically resumes operation in about 3 minutes. You should just wait for a while.
- Lightning
If lightning may strike the neighbouring area, stop operation and turn the breaker OFF for system protection.

Disposal requirements



Your product and the batteries supplied with the controller are marked with this symbol. This symbol means that electrical and electronic products and batteries shall not be mixed with unsorted household waste.

For batteries, a chemical symbol can be printed beneath the symbol. This chemical symbol means that the battery contains a heavy metal above a certain concentration. Possible chemical symbols are:

Pb: lead (>0.004%)

Do not try to dismantle the system yourself; the dismantling of the product, treatment of the refrigerant, of oil and of other parts must be done by a qualified installer in accordance with relevant local and national legislation.

Units and waste batteries must be treated at a specialized treatment facility for re-use, recycling and recovery.

By ensuring correct disposal, you will help to prevent potential negative consequences for environment and human health.

Please contact the installer or local authority for more information.

Dismantling of the unit, treatment of the refrigerant, of oil and of other parts must be done in accordance with relevant local and national legislation.

We recommend periodical maintenance.

In certain operating conditions, the inside of the air conditioner may get foul after several seasons of use, resulting in poor performance. It is recommended to have periodical maintenance by a specialist aside from regular cleaning by the user. For specialist maintenance, contact the service shop where you bought the air conditioner.

The maintenance cost must be borne by the user.

Important information regarding the refrigerant used.

This product contains fluorinated greenhouse gases covered by the Kyoto Protocol.

Refrigerant type: R410A

GWP⁽¹⁾ value: 1975

⁽¹⁾ GWP = global warming potential

Periodical inspections for refrigerant leaks may be required depending on European or local legislation. Please contact your local dealer for more information.

DAIKIN INDUSTRIES CZECH REPUBLIC s.r.o.

U Nové Hospody 1/1155, 301 00 Plzeň Skvrňany, Czech Republic

DAIKIN EUROPE N.V.

Zandvoordestraat 300, B-8400 Oostende, Belgium

Copyright 2014 Daikin

4P393320-1 2014.12